

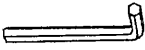

















80027 Rolling Workcenter

Assembly Instructions

HARDWARE

- | | |
|--|---|
| A Allen Wrench

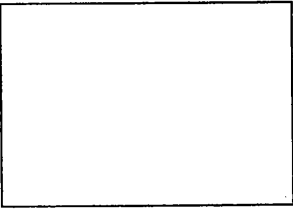
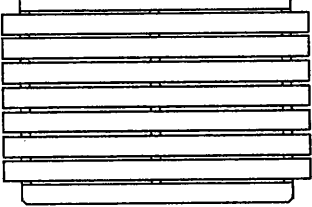
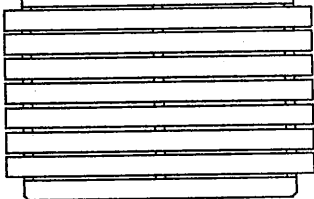
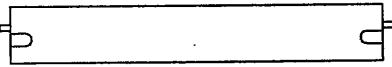
M4 x1 | J Wood Button

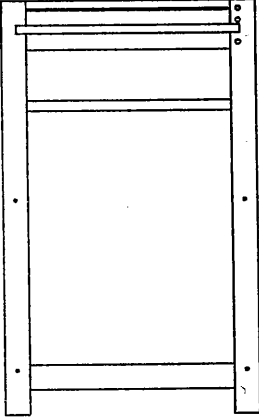
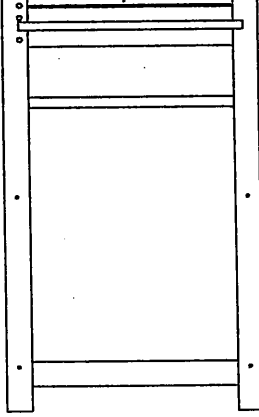
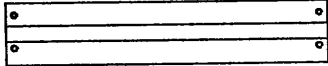
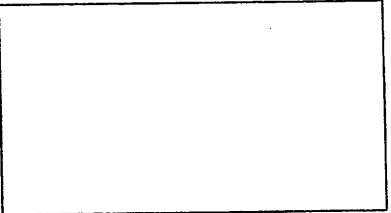
M13 x4 |
| B JCBC

M6 x 40mm x8 | K THCB Screw

M4 x 16mm x4 |
| C Metal Pin

M6 x4 | L Knob

x1 |
| D Wood Dowel

M8 x 30mm x2 | M Panhead Screw

5/32 x 30mm x1 |
| E Locking Caster

x4 | N Wood Screw

M4 x 30mm x8 |
| F Spring Washer

M10 x4 | P 'Z' Bracket

x4 |
| G Flat Washer

M10 x4 | R Plastic Stopper + THCB Screw

x1 
M4 x 16mmx1 |
| H Spanner

x1 | |

PARTS

- | | | |
|--|--|--|
| ① 
Top Panel x 1pc | ⑤ 
Mid Slatted Shelf x 1pc | ⑥ 
Bottom Slatted Shelf x 1pc |
| ② 
Back Panel x 1pc | ⑦ 
Drawer Front x 1pc | ⑧ 
Drawer Back x 1pc |
| ③ 
Side Panel (left) x 1pcs | ④ 
Side Panel (right) x 1pcs | ⑨ 
Drawer Side x 2pcs |
| | | ⑩ 
Drawer Base x 1pc |

IMPORTANT! DO NOT TIGHTEN SCREWS OR BOLTS UNTIL COMPLETELY ASSEMBLED!!

Customer Service 0607 - 652 7321

80027 Rolling Workcenter Assembly Instructions

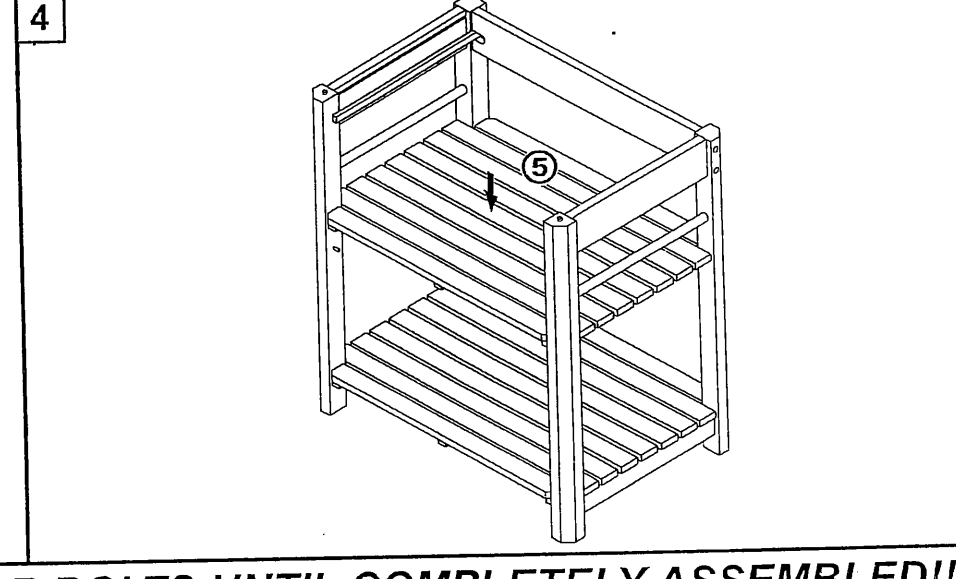
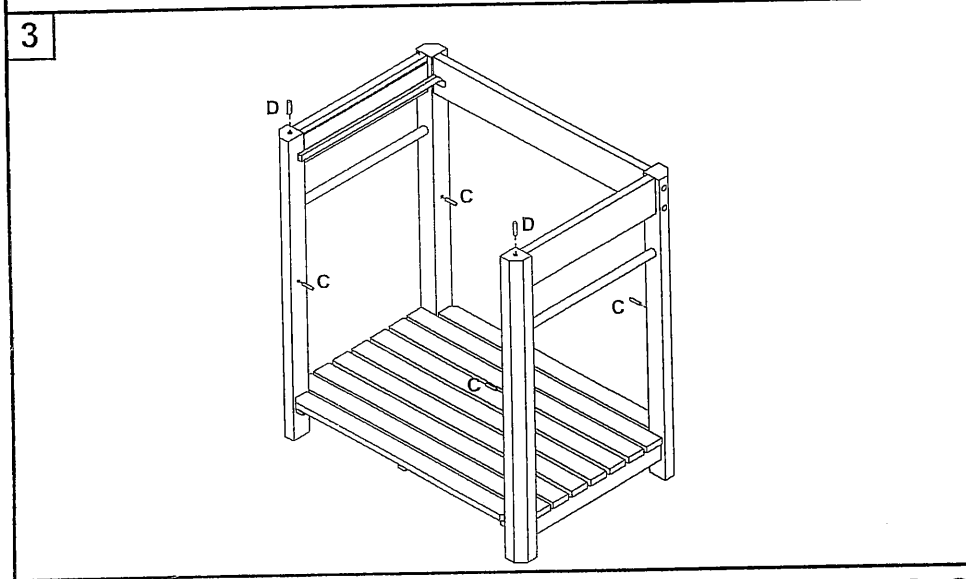
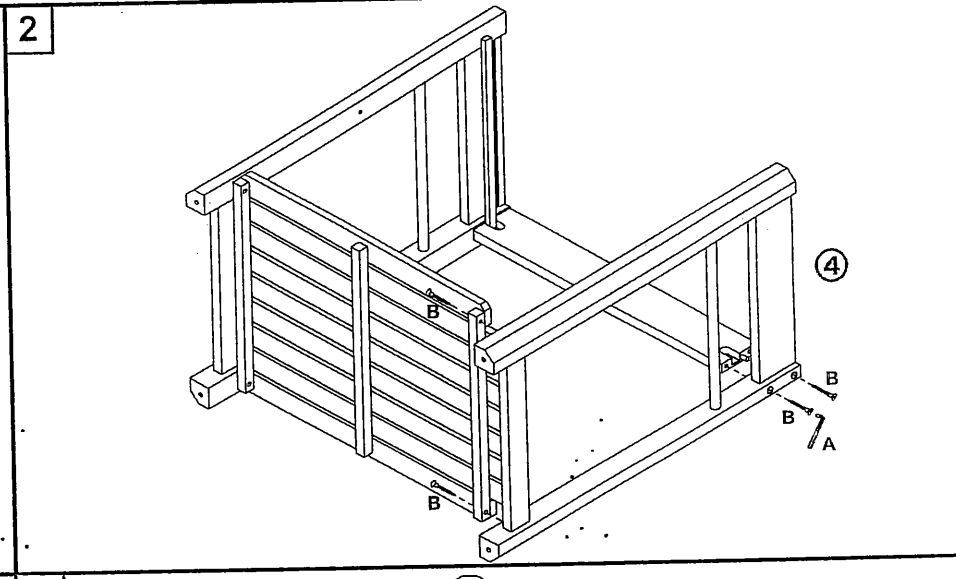
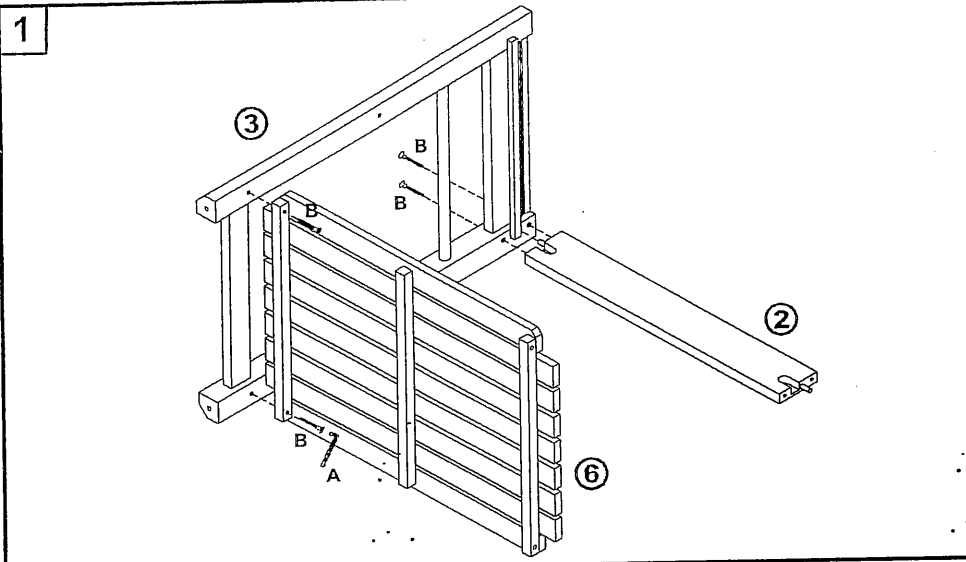

IMPORTANT! DO NOT TIGHTEN SCREWS OR BOLTS UNTIL COMPLETELY ASSEMBLED!!

Customer Service 0607 - 652 7321

80027 Rolling Workcenter

Assembly Instructions

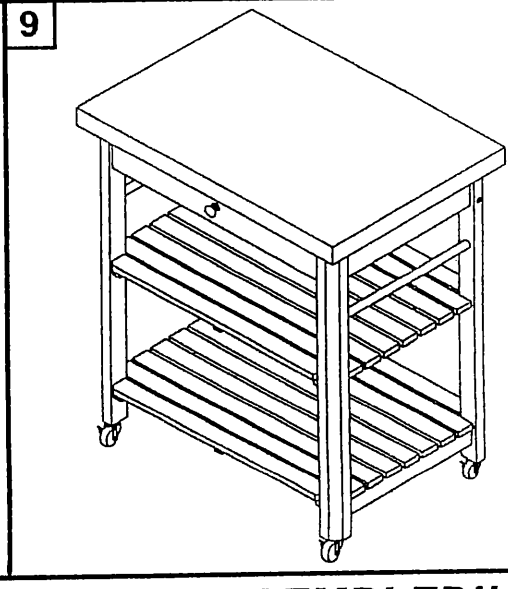
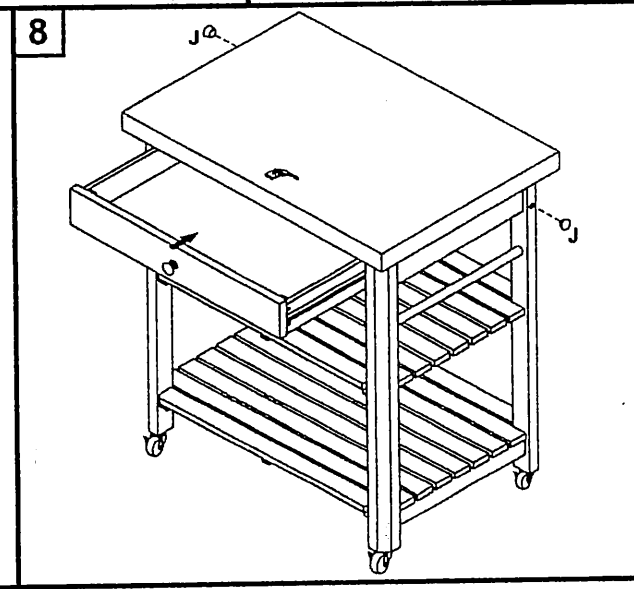
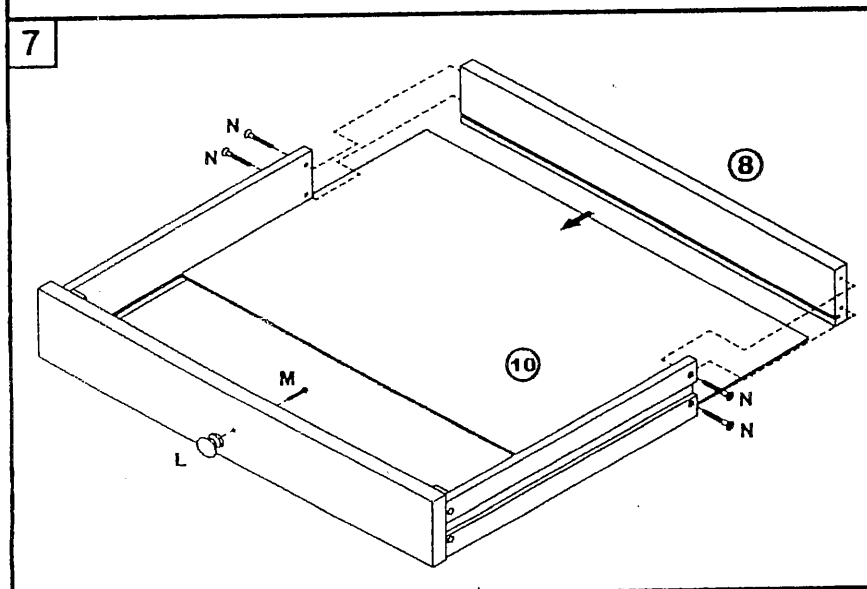
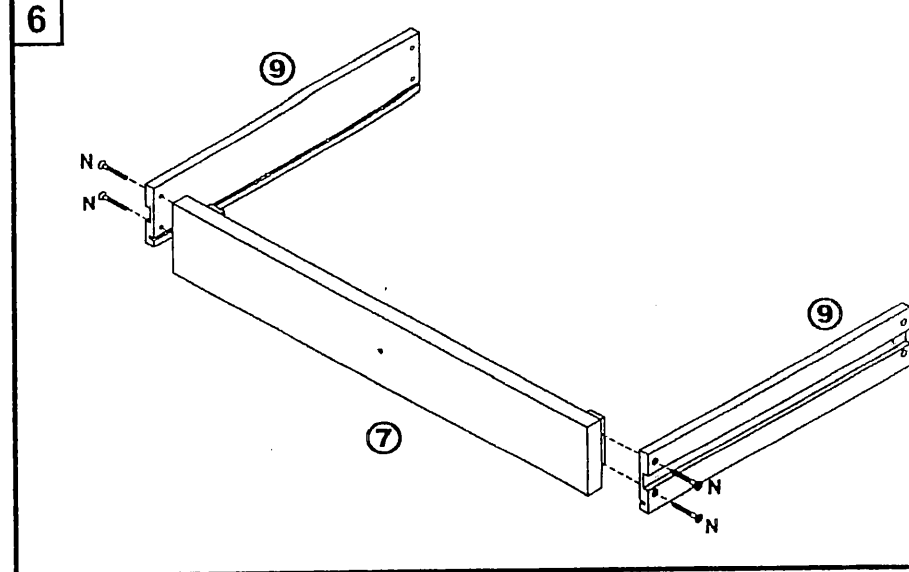
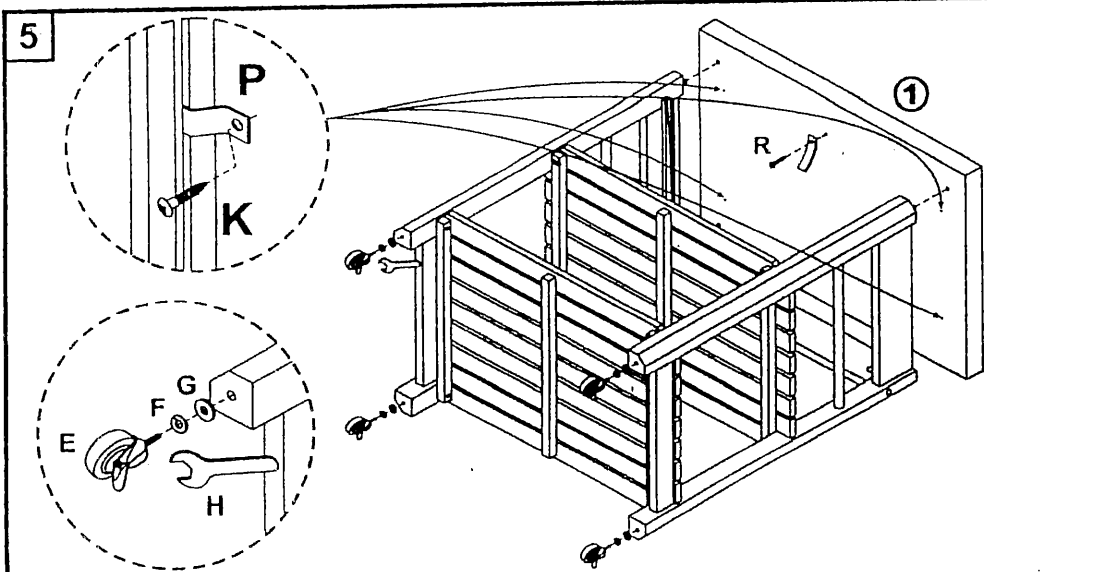

IMPORTANT! DO NOT TIGHTEN SCREWS OR BOLTS UNTIL COMPLETELY ASSEMBLED!!

Customer Service 0607 - 652 7321