

# Solid Hard Rock Maple Book - Magazine - Video Display Rack With Cork Board at the Top

**Model 3340**



## **FEATURES**

- Solid Hard Rock Maple with Tough Lacquer Finish
- Six Adjustable Shelves — Expandable to Ten (extra shelves sold separately - Model 3341)
- The 8" Deep Tilted Shelves allow for Spine-out or Full Cover Display of Books or Video Cassettes
- Two Cork Bulletin Boards — 42" x 12"
- Overall Rack is 60" High x 42" Wide x 45" Deep
- Easily Assembled with Common Tools
- Drop Shipments Available via U.P.S. or Common Carrier

 **CATSKILL CRAFTSMEN, INC.**

15 West End Avenue, Stamford, N.Y. 12167-1296 (607)652-7321

MODEL 3340  
DISPLAY RACK WITH CORK BOARDS

ASSEMBLY INSTRUCTIONS

PARTS LIST:

A-Frame Leg Assemblies	2 Hinged at factory.
Cork Boards	2 Factory Assembled
Shelf Ends	12 (6 Left & 6 Right)
Shelf Backs	6 Narrowest shelf 6 5/8" Wide
Shelf Bottoms	6 Widest 7 3/8" Wide
Pan Head 3/4" #8 Screws	32 Used on shelf backs to attach to A-Frame
Phillips Head 1 3/4" #8 Screws	48 Used to attach shelf parts
Washers	4 Used with support sticks
Wing Nuts (or Square Nuts)	4 Used with support sticks
Support Sticks	2 Used to support A-Frames

STEP 1: To assemble shelves, set the Shelf Back on top of the Shelf Bottom. Make sure the 4 pilot holes in the Shelf Back face backward, & the 4 countersunk holes in the Shelf Bottom face downward. Attach the Shelf Ends (1 left & 1 Right--countersunk holes face out) with 1 3/4" Screws, making sure the wood grain runs the same way on both ends. Ends are bored so that the wood grain can run either vertically or horizontally. With ends in place, rotate shelf so that the four countersunk holes in the Shelf Bottom are facing up. Attach the Shelf parts with 1 3/4" Screws, making sure all 4 screw points are in the pilot holes before tightening down. Repeat with all 6 shelves. See Illus. 1.

STEP 2: Take Assembled shelves & cork boards and screw four 3/4" Pan Head screws into the pilot holes in the back sides of the Shelf/Cork Boards, leaving approximately the thickness of 3 pennies clearance between the back of the screw head and the Shelf Back. These Screws may have to be tightened a little more in Step 4.

STEP 3: Take one A-Frame Leg Assembly and attach one Support Stick as shown in Illus. 2, using Washers & Wing Nuts to secure. These sticks will go on the INSIDE sides of the A-Frame when unit is assembled in Step 4.

STEP 4: Upright A-Frame Assemblies and attach one shelf on either side by aligning the Pan Head Screws in the Shelf Backs with the key hole slots in the A-Frame. Make sure the fit is tight. If not, remove Shelf & tighten Pan Head Screw(s) until a tight fit is obtained. If necessary, tap down on top of Shelf with a rubber hammer for an even tighter fit. A sloppy fit will allow the unit to have a little lateral movement and effect the sturdiness of the unit after the unit is loaded. Make sure the Support Sticks are on the inside. Space & attach other Shelves as required. Cork Boards can be attached to the A-Frame using both Pan Head Screws into the keyhole slots, or they can be installed using just the bottom screw with the tops touching each other as shown. Again, make sure the fit is tight.

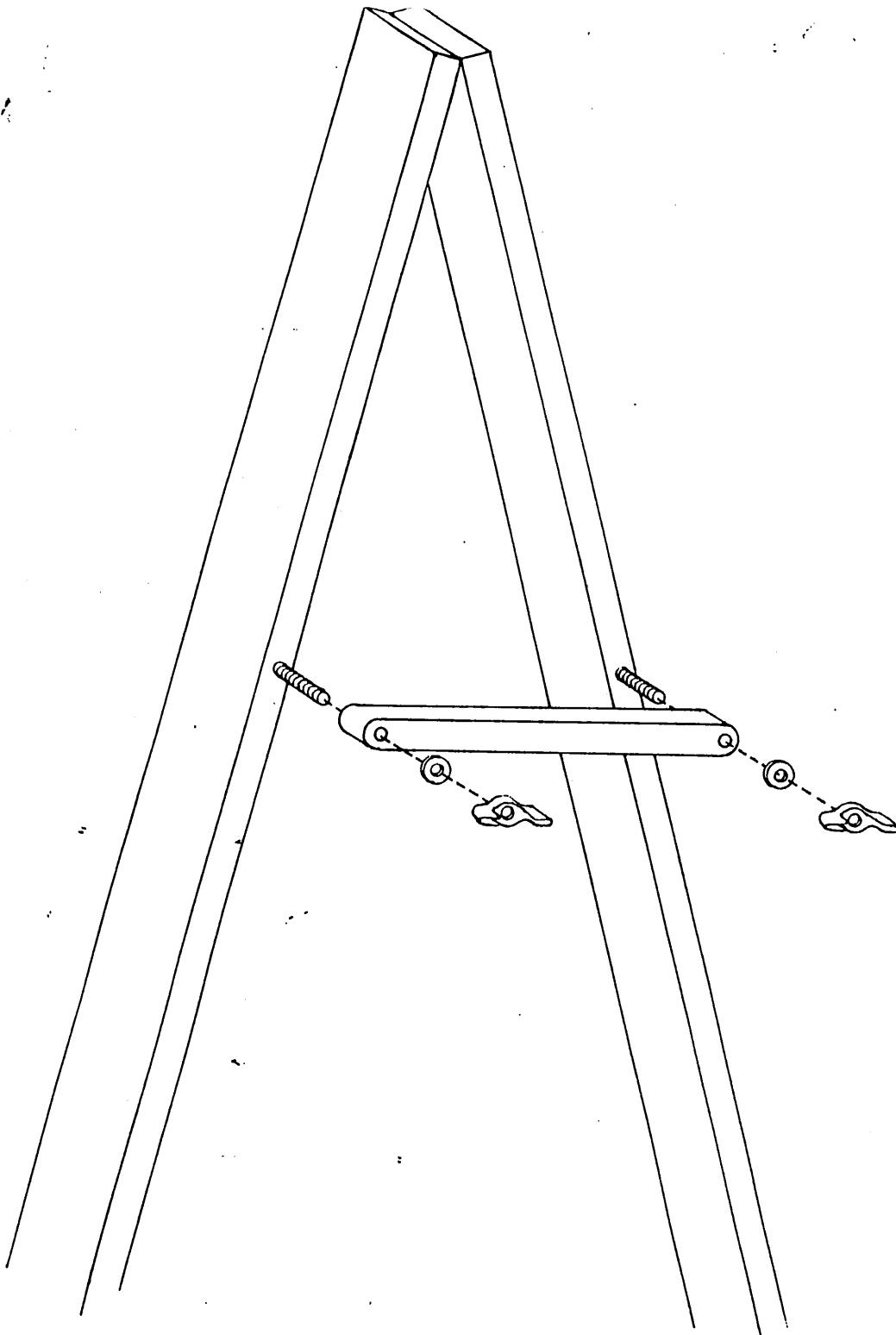

Illust. # 2

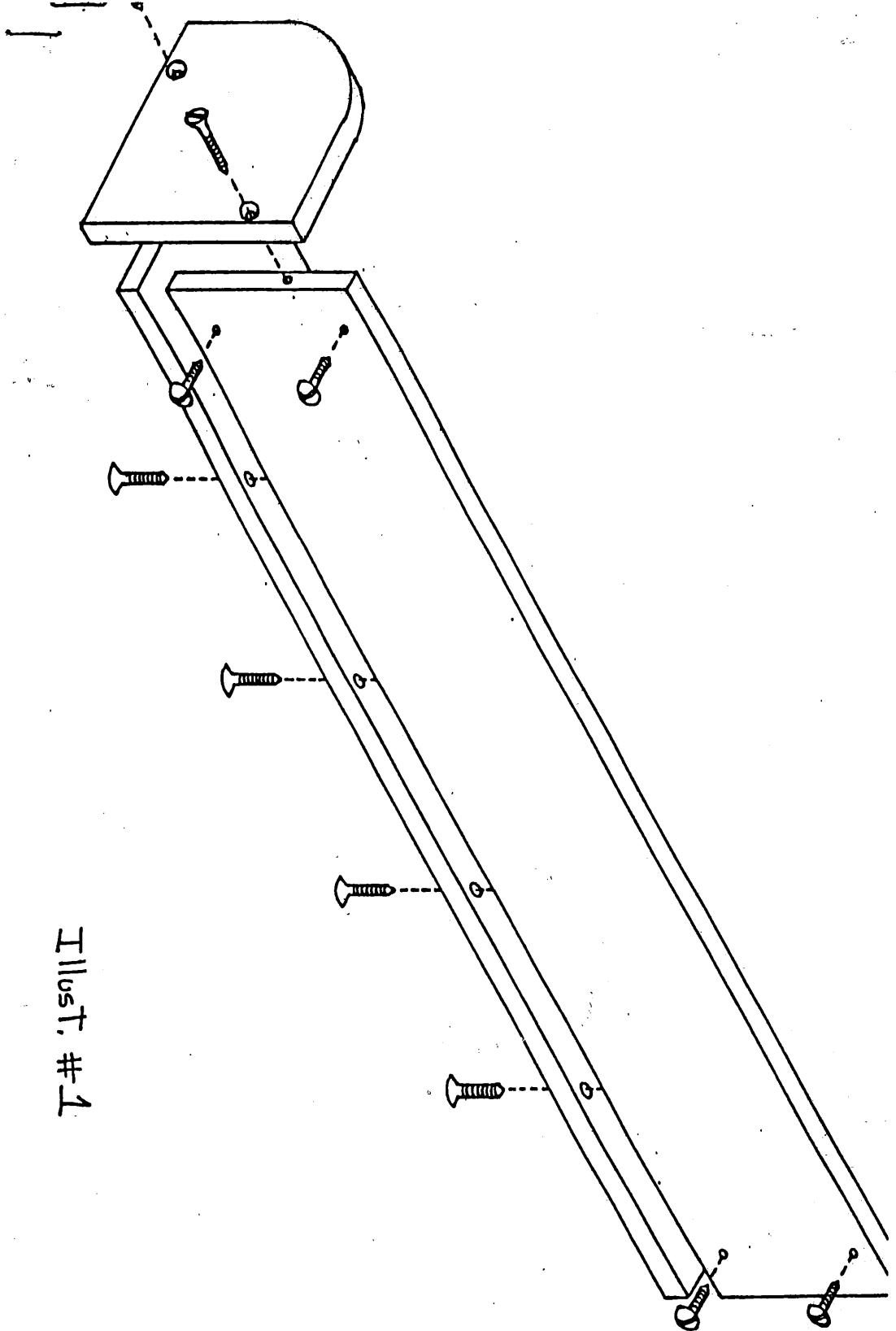

Illust. # 1

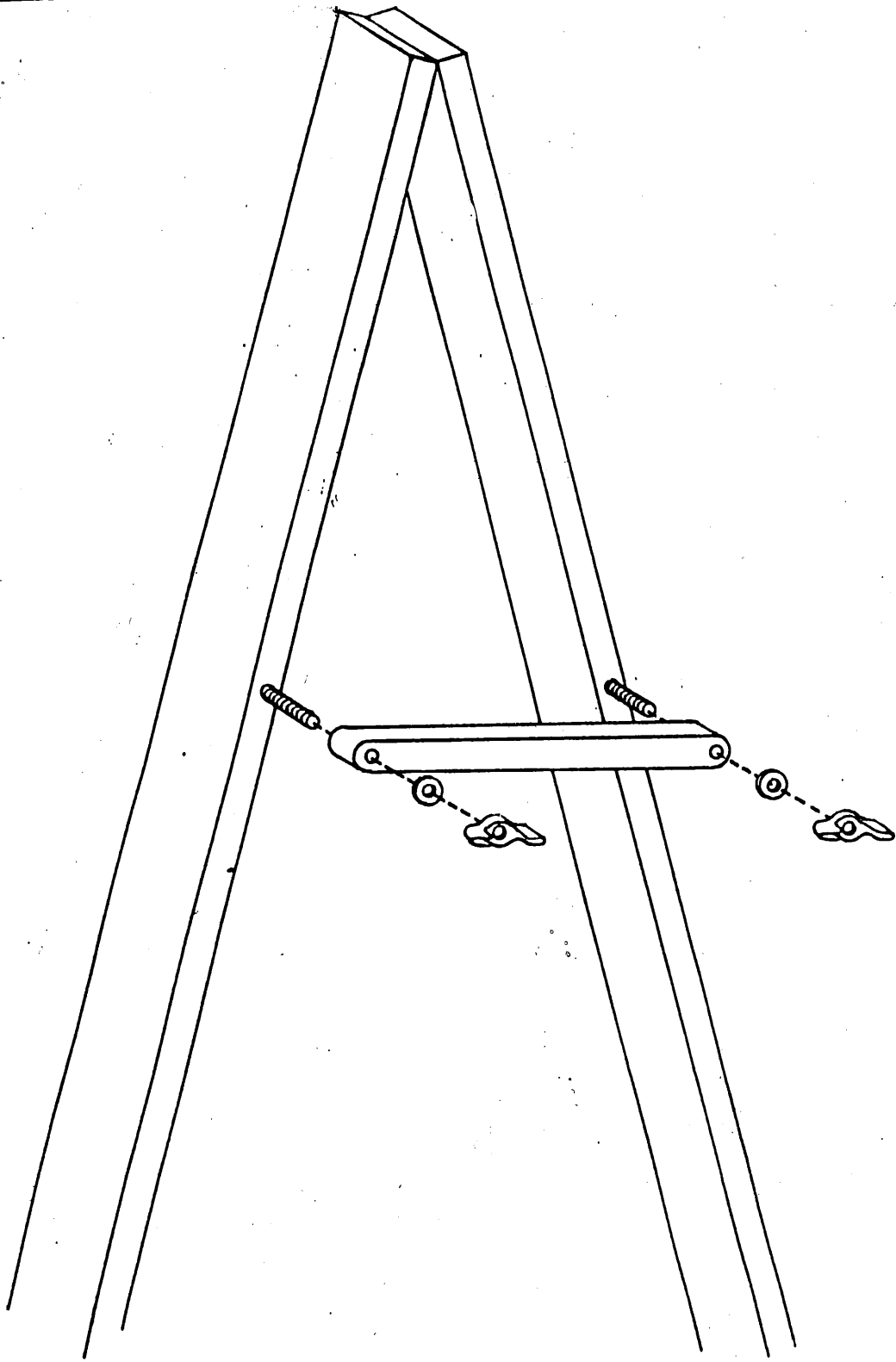

Illust. # 2