

# CATSKILL

C R A F T S M E N , I N C .

## Assembly Instructions Model 1622 Fold-A-Way Table



**GENERAL:** Your folding table has been engineered to fit together with a minimum of effort if you follow the instructions step-by-step. Assembly should take about an hour.

The only tools you need are a medium Phillips screwdriver and a hard hammer. A flat scrap of wood or plastic will come in handy to protect surfaces when hammering to seat braces or disks. A power screwdriver will speed assembly, but is not necessary. A little vegetable oil on the wood screw threads will make it easier to attach the feet to the table ends/sides.

Read through the instructions completely to familiarize yourself with the various parts and the progression of the assembly process. Inventory your parts against the parts list. If anything is missing or damaged, contact us directly for prompt, free parts replacement.

Once your table is assembled, remember that it is made of solid northeastern hardwood and will need to be cared for as outlined in the enclosed booklet, "All About Your Butcher Block Unit." Your table is designed to open either leaf individually or both leaves. When folded, the unit takes up only 10" of outward space. Holes in the Table end/sides are hand holes for easy movement of the 37 lb. unit. Casters are not practical on this unit as it would make the unit top heavy if elevated on casters.

See our assembly video for this model on our website: [www.catskillcraftsmen.com](http://www.catskillcraftsmen.com)

# PARTS LIST

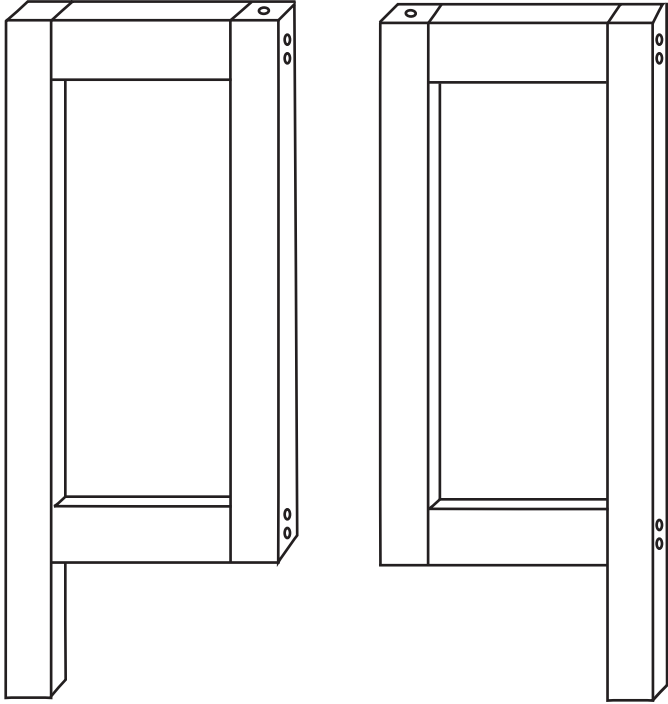

(2) Factory Assembled Swing Legs (Identical)

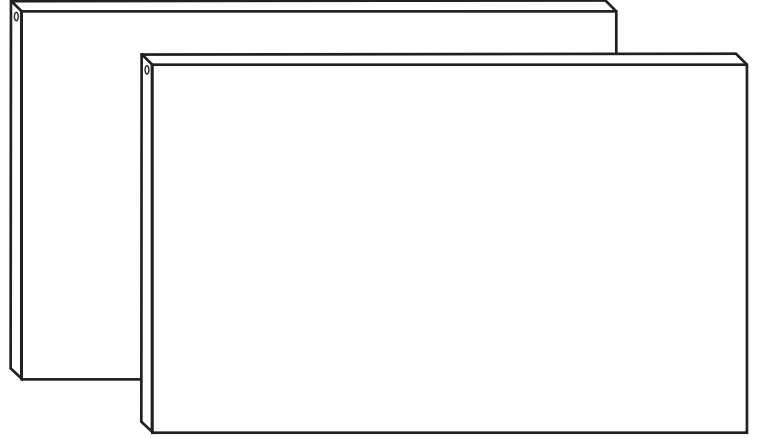

(2) Drop Leaves (Identical)



(1) Top Support Brace for Main Frame (3" Wide)

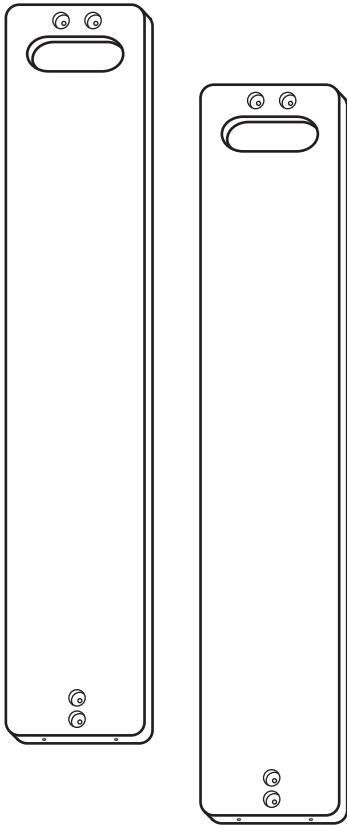

(2) Table Ends/Sides (Identical)



(1) Bottom Support Brace for Main Frame (2" Wide)



(2) Feet for Main Frame (Identical)



(8) 5/8" Wooden Disks Fit in Holes on Table Ends/Sides (Identical)



(8) 2" Machine Screws (Bolts) for Basic Assembly



(8) Nuts for Machine Screws

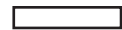

(4) 3/4" Steel Pins



(4) 1 1/2" Steel Pins



(6) Small Washers for Pivot Pins

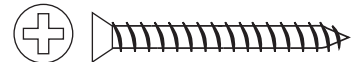

(4) 1 3/4" Long #8 Wood Screws to Attach Feet

# STEP 1

**Tools needed:** medium Phillips screwdriver

**Hardware needed:** (4) wood screws 1 3/4" #8

**Parts needed:** (2) Table Ends, (2) Feet

**Preparation:** dip screw tips in vegetable oil to ease installation of screws into hardwood.

Invert Table ends (identical) and attach feet (identical) with 1 3/4" #8 screws as shown in illustration 1

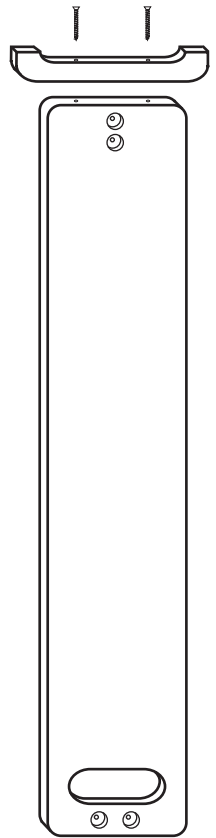

Illustration 1

# STEP 2

**Tools needed:** medium Phillips screwdriver

**Hardware needed:** (4) 2" machine screws and (4) nuts

**Parts needed:** Table Ends with feet attached and the bottom support brace

Join the leg assemblies at bottom support brace using (2) machine screws/nuts per side. Place nut on finger tip, insert into the nut access hole in the brace, align with machine screw and loosely tighten so that frame stands alone.

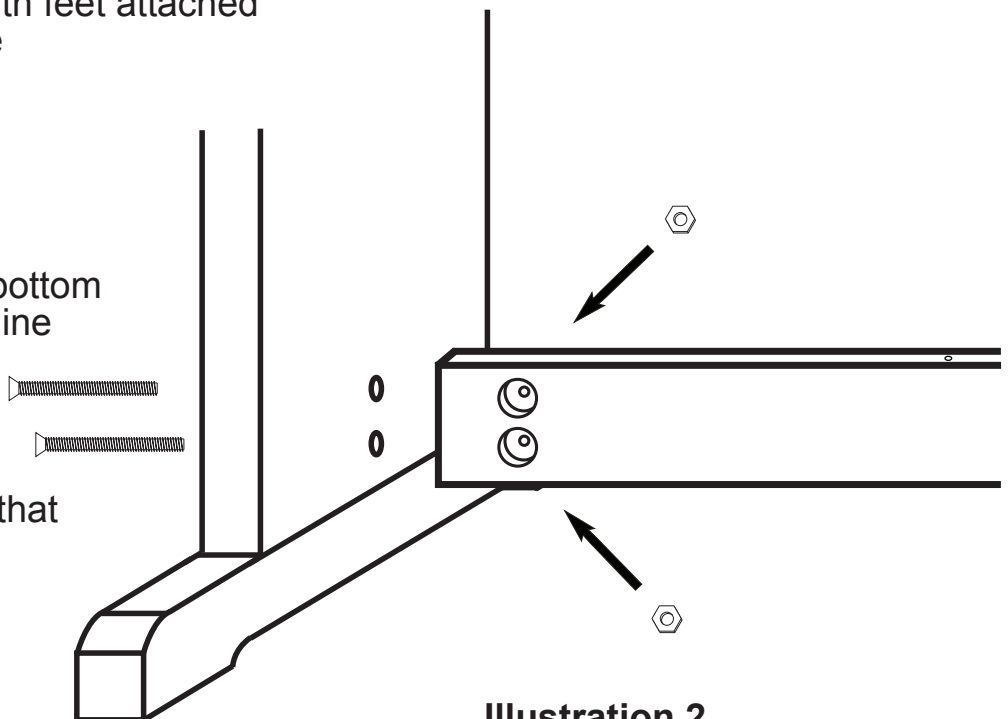

Illustration 2

## STEP 3

**Tools needed:** Hammer

**Hardware needed:** (4) 3/4" Steel pins (shortest)

**Parts needed:** Frame from step 2,  
and 2 swing legs (identical)

Insert/Tap (2) 3/4" steel pins into the short vertical brace of each factory assembled swing leg as in illustration 3.

**DO NOT OVERDRIVE PINS!** When seated, pins should have 3/8" sticking out of the brace ends.

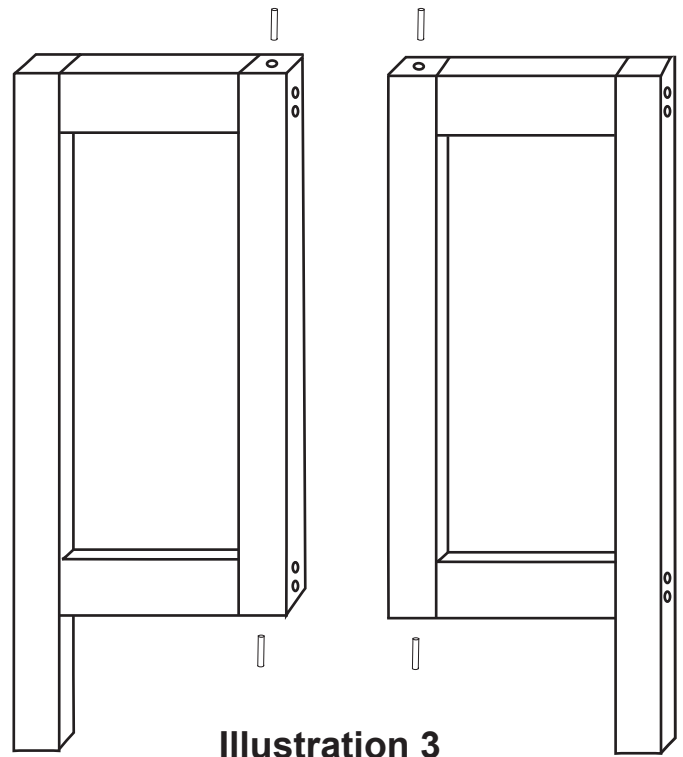

**Illustration 3**

**NOTE:** If pins are loose in the bottom of the swing legs, simply insert them in the top edge of the bottom support brace in step 4

## STEP 4

**Tools needed:** None

**Hardware needed:** (2) washers

**Parts needed:** Basic Frame, Swing legs

Place one washer over each of the bottom pins in the swing legs and insert pins into the holes in the top edge of the bottom support brace as shown in illustration 4

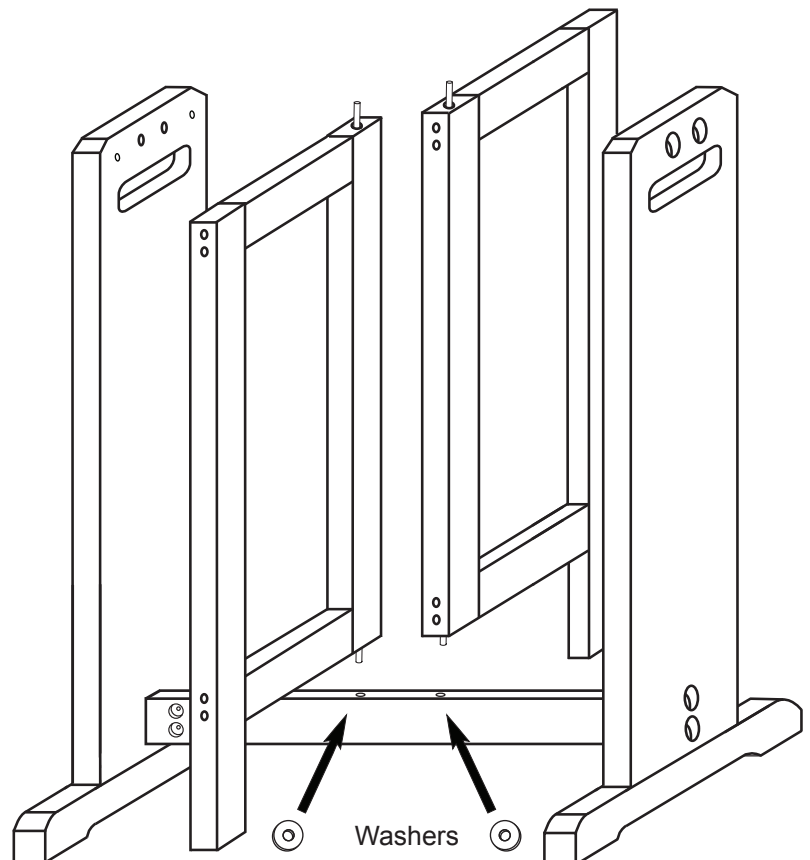

**Illustration 4**

## STEP 5

**Tools needed:** Hammer

**Hardware needed:** (4) 1 1/2" Steel pins (longest)

**Parts needed:** (2) Drop Leaves

Tap one 1 1/2" long pin into each end of both drop leaves until seated. When seated, pin will stick up about 3/4" out of the wood. **CAUTION! Don't overdrive pins or wood will split!**

**OK if Pins are loose!**

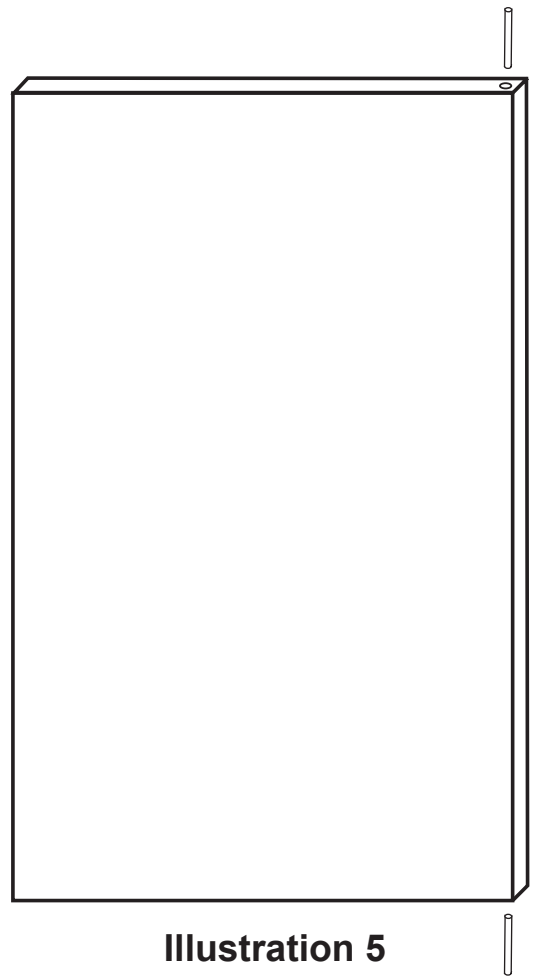

**Illustration 5**

## STEP 6

**Tools needed:** None

**Hardware needed:** (4) washers

**Parts needed:** Basic assembly plus 2 Drop Leaves

Gently spread the tops of the table ends/sides apart and insert the drop leaf pins (with one washer over each pin) into the pre-drilled holes on the top inside of the table ends/sides. Place swing legs as shown in illustration 6 to support the drop leaves.

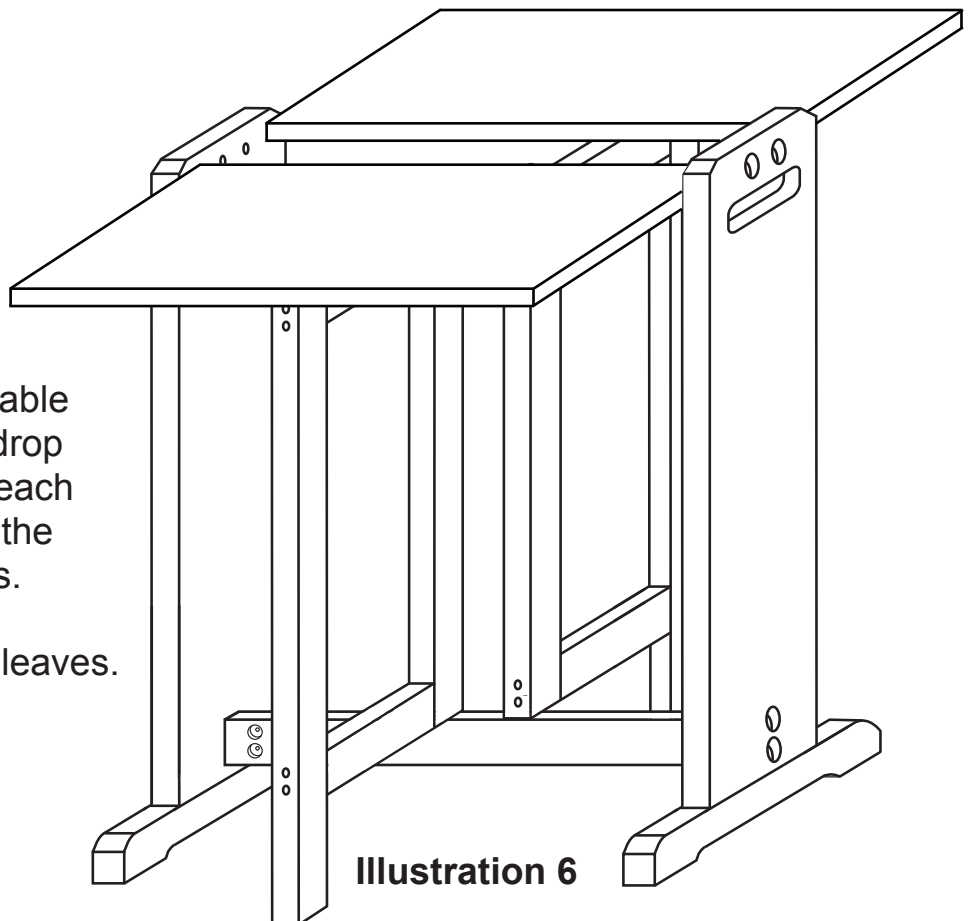

**Illustration 6**

## STEP 7

**Tools needed:** medium Phillips screwdriver

**Hardware needed:** (4) 2" machine screws (bolts) and (4) nuts

**Parts needed:** Basic assembly plus top support brace

Take the top support brace with the 2 pin holes and 4 nut access holes (larger) facing down and align the pin holes with the pins on the top edges of the swing legs.

**NOTE:** These pins do not get washers! If necessary, tap down on the top of the brace to seat the pins. **CAUTION! Hammer down on a scrap of flat wood or plastic so as not to mar the top surface of the brace.**

When seated, secure brace with machine screws/nuts as in illustration 7

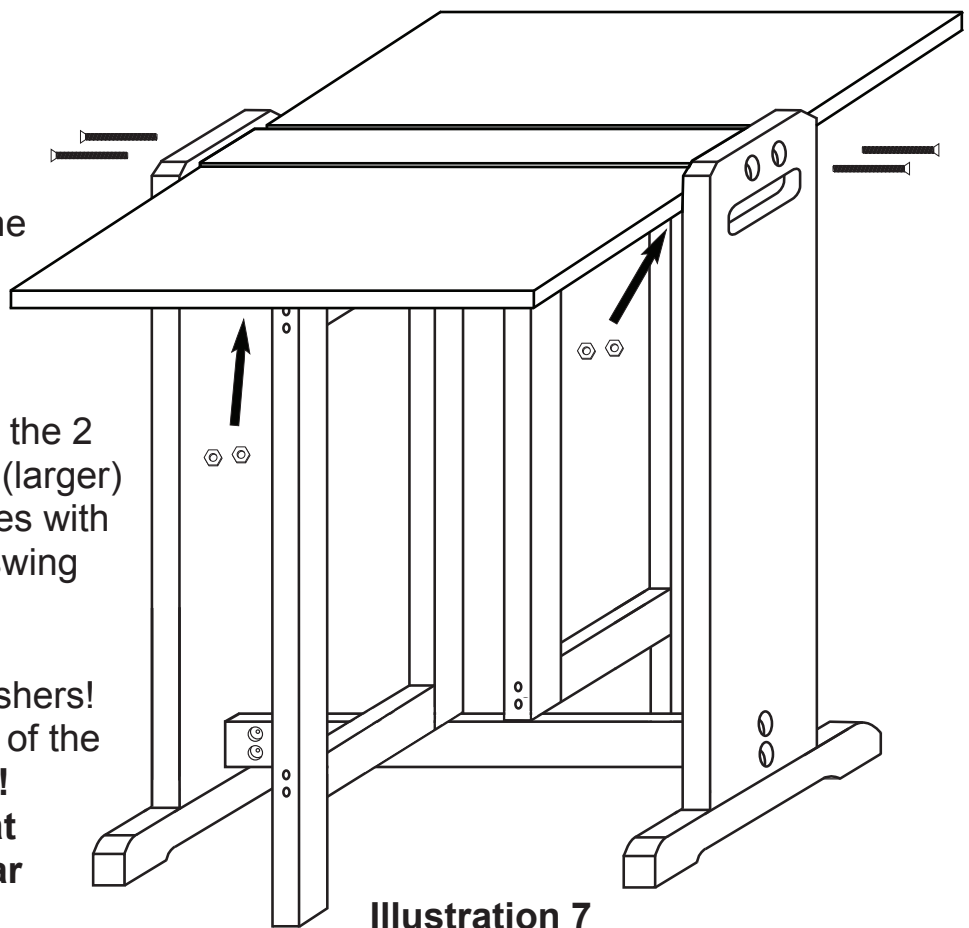

## STEP 8

**Tools needed:** medium Phillips screwdriver, hammer

**Hardware needed:** (8) 5/8" wooden disks (small)

**TIP:** Use a piece of heavy paper to hammer on instead of directly on wooden disks.

Tighten all machine screws/nuts. Tap in (4) 5/8" disks into each table end/side as shown in illustration 8.

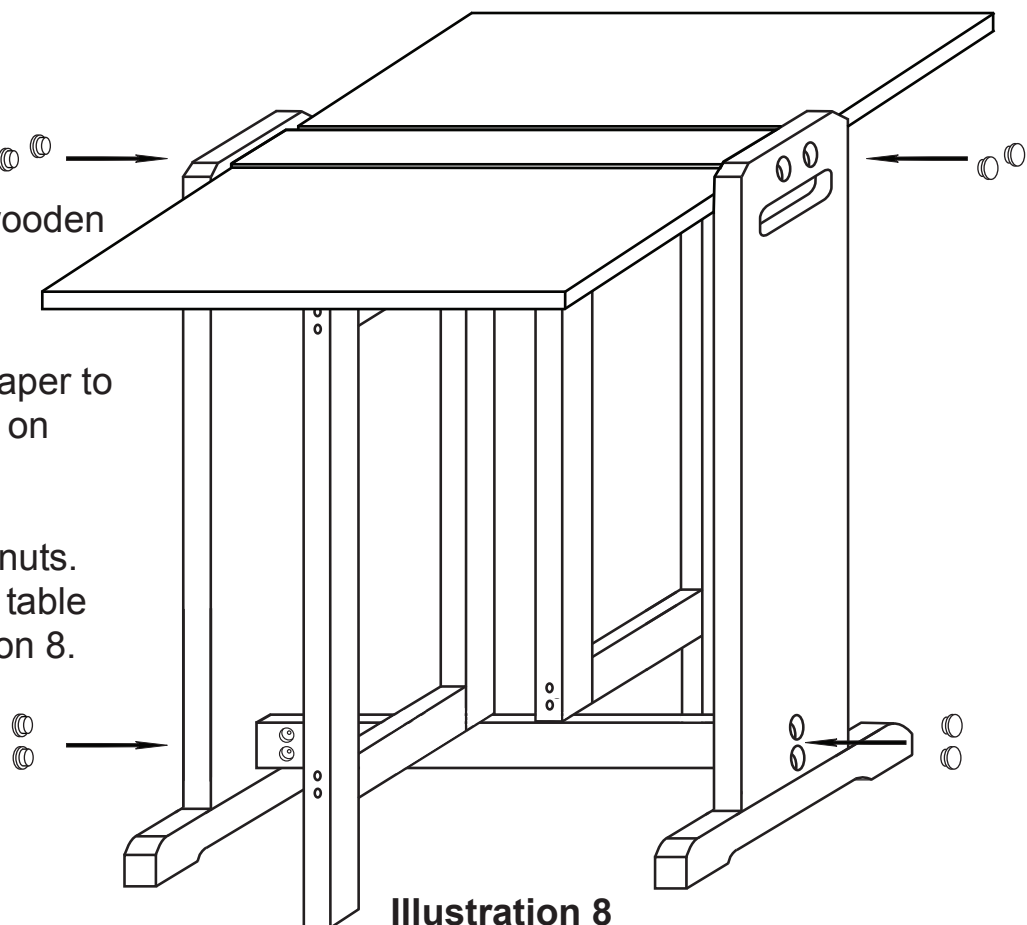



For continued beauty and long life of your Catskill Craftsmen cart, we recommend Catskill Craftsmen's Butcher Block Oil.

If you would like to purchase Butcher Block Oil directly from Catskill Craftsmen's factory, we offer a reduced price. For one eight ounce (8 fl. oz.) bottle, which is sufficient for two applications, simply send \$6.95 along with the completed coupon to the address below.



Catskill Craftsmen, Inc.  
15 West End Ave.  
Stamford, NY 12167-1296

  
**CATSKILL**  
CRAFTSMEN, INC.

### BUTCHER BLOCK OIL COUPON

Please send me \_\_\_\_\_ # of bottle(s) of the  
Catskill Craftsmen Butcher Block Oil at \$6.95.  
My Check or Money Order is enclosed for a  
total of \$\_\_\_\_\_.

Item Code: 1622

NAME \_\_\_\_\_

ADDRESS \_\_\_\_\_  
\_\_\_\_\_

CITY \_\_\_\_\_

STATE \_\_\_\_\_ ZIP \_\_\_\_\_

Please make checks payable to: Catskill Craftsmen Inc.  
15 West End Ave. Stamford, NY 12167-1296